



Level Switch

NRS 2-4

EN
English

Original Installation Instructions
810427-03

Contents

Page

Important Notes

Usage for the intended purpose	4
Safety note	4
Danger	4
Attention	4
LV (Low Voltage) Directive and EMC (Electromagnetic Compatibility)	4
ATEX (Atmosphère Explosible).....	4

Explanatory Notes

Scope of supply	5
Description	5
Function	5
Design	5

Technical Data

NRS 2-4.....	6
Dimensions.....	7

Functional Elements

NRS 2-4.....	8
Key	8

Installation

NRS 2-4c.....	9
NRS 2-4d.....	9
Tools.....	9

Electrical Connection

NRS 2-4.....	10
Wiring diagram	10
Key	11
Attention	11
Note	11
Tools.....	11

Contents – continued –

Page

Commissioning Procedure

Checking electrical connection	12
Applying mains voltage.....	12
Danger	12
Performance test	12
Table 1	12

Operational Malfunctions

Danger	13
Fault finding list for troubleshooting	13

Annex

Note on the Declaration of Conformity / Declaration by the Manufacturer CE	14
--	----

Important Notes

Usage for the intended purpose

The level switch NRS 2-4 is used in conjunction with level electrode NRG 211 and signals a maximum admissible liquid level.

Safety note

The level switch is a safety device and must only be installed, wired and commissioned by qualified and competent staff.

Retrofitting and maintenance work must only be performed by qualified staff who – through adequate training – have achieved a recognised level of competence.



Danger

The terminal strip of the NRS 2-4 is live during operation.
This presents the danger of electric shock!

Cut off power supply before inserting or removing the 19" slide-in unit and before carrying out any installation or maintenance work.



Attention

The name plate specifies the technical features of the equipment. Note that any piece of equipment without its specific name plate must neither be commissioned nor operated.

LV (Low Voltage) Directive and EMC (Electromagnetic Compatibility)

The level switch NRS 2-4 meets the requirements of the Low Voltage Directive 2014/35/EC and the EMC Directive 2014/30/EC.

ATEX (Atmosphère Explosible)

According to the European Directive 2014/34/EC the level switch NRS 2-4 must **not** be used in potentially explosive areas.

Explanatory Notes

Scope of supply

NRS 2-4c

- 1 Level switch designed as 19" slide-in unit, front panel to DIN 41494, part 5, 6 division units*)
- 2 Guide rails
- 1 Screw-type connector
- 1 Installation manual

NRS 2-4d

- 1 Level switch designed as 19 slide-in unit, front panel to DIN 41494, part 5, 6 division units*)
- 1 Installation manual

Description

The level switch NRS 2-4 is an analogue electronic amplifier for the capacitance electrode NRG 211. In conjunction with the electrode NRG 211 it can detect high water level. In addition, the level switch detects possible malfunction signals coming from the electrode and monitors the electrode supply cable.

Function

The NRS 2-4 is a single-channel device equipped with a power supply unit and a voltage detector. The feed voltage (12 V DC) for the electrode is – depending on the operating condition – converted into a measuring voltage. The signal decoder allocates the measuring voltage to an operating condition which is indicated by the LEDs on the front panel of the NRS 2-4.

The level switch can signal the following four operating conditions:

- Normal operation
- High level alarm
- Malfunction in level electrode
- Malfunction in connecting cable

In the event of a high level alarm or malfunction the corresponding output relay will be triggered. In addition to the output relays optocouplers are also available for switching.

Design

NRS 2-4c:

19 slide-in unit with guide rails and 32 pole screw-type connector for installation in 19 magazine to DIN 41494, part 5. Front panel to DIN 41494, part 5, 6 division units*).

NRS 2-4d:

Spare 19 slide-in unit, front panel to DIN 41494, part 5, 6 division units.

*) 1 division unit = 5.08 mm

Technical Data

NRS 2-4

Input measuring circuit

1 V to 10 V DC (measuring voltage coming from level electrode)

Output measuring circuit

12 V DC (supply voltage for level electrode)

Output

2 volt-free relay contacts. Max. contact rating with switching voltages of 24 V, 115 V and 230 V AC: resistive 4 A, inductive 0.75 A at $\cos \varphi$ 0.5.

Max. contact rating with switching voltage 24 V DC: 4 A. Contact material silver, hard gold plated.

2 optocouplers (NPN), short-circuit protected due to current limiting, max. 70 V, 10 mA

Indicators and adjustors

1 LED for "Alarm", 2 LEDs for "Malfunction", 1 LED for "Power"

Mains voltage

18 - 36 V DC

Power consumption

2 VA

Housing material

NRS 2-4c: Front panel: aluminium

NRS 2-4d: Front panel: aluminium

Weight

NRS 2-4c/d: approx. 0.6 kg

Dimensions

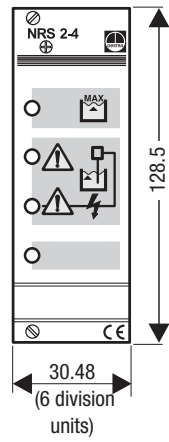
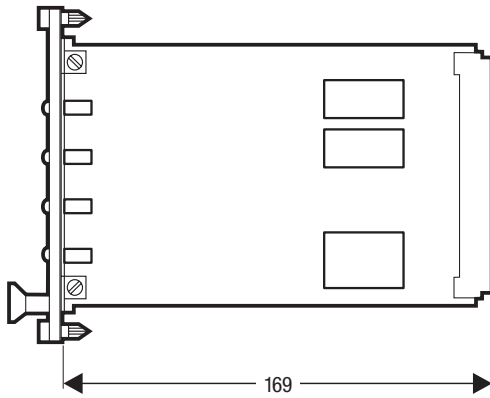

Fig. 1

Functional Elements

NRS 2-4

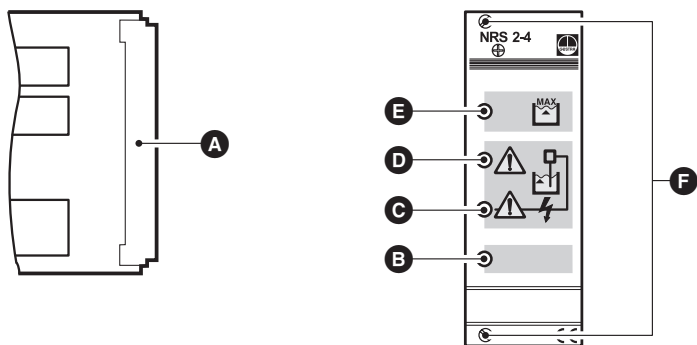

Fig. 2

Key

- A** 32-pole screw-type connector, DIN 41612, design D
- B** LED "Power"
- C** LED "Malfunction in connecting line"
- C** LED "Malfunction in level electrode"
- E** LED "High level alarm"
- F** Fixing screws

Installation

NRS 2-4 c

1. Mount plastic guide rails in 19 magazine.
2. Install screw-type connector.
3. Insert level switch in 19 magazine and fix it with screws **F**.

NRS 2-4 d

1. Insert level switch in 19 magazine and fix it with screws **F**.

Tools

- Screwdriver 5.5/100

Electrical Connection

NRS 2-4

Note that screened four-core cable, e. g. I-Y(St)Y 2 x 2 x 0.8 or LIYCY 4 x 0.52 is required for wiring.
Max. length: 500 m.

Wire screw-type connector according to the wiring diagram. **Fig. 3**

Wiring diagram

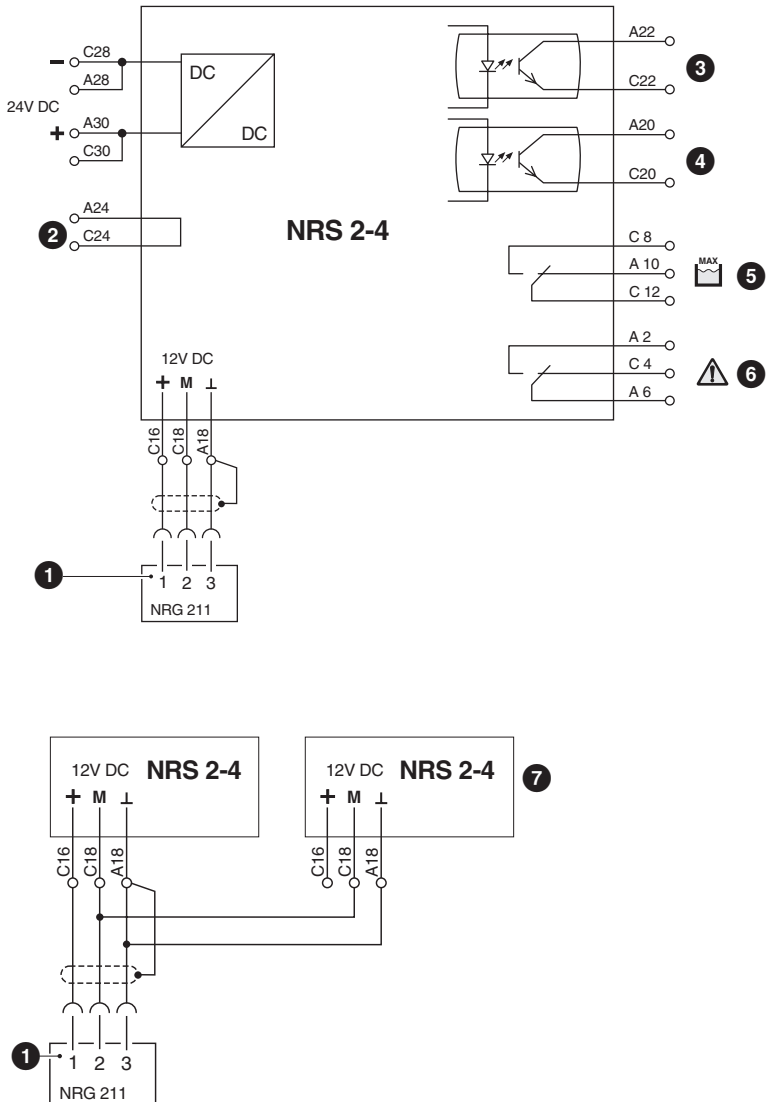

Key

- 1 Level electrode NRG 211
- 2 Test loop for equipment
- 3 Switching output for “Alarm” (optocoupler)
- 4 Switching output for “Malfunction” (optocoupler)
- 5 Switching output for “Alarm” (relay)
- 6 Switching output for “Malfunction” (relay)
- 7 Wiring diagram for two high-level switches installed in parallel (redundancy)



Attention

- To protect the switching contacts fuse circuit with 2.5 A (slow-blow) or according to TRD regulations (1.0 A for 72 h operation).
- The screen must not make any other electrical contact



Note

- Connect screen only to terminal A18 of the level switch.
- The monitoring of the level electrode and the connecting lines can be included in the safety circuit. For this purpose the safety circuit must also be fed to the relay output “Malfunction”.
- The rated voltage is indicated on the name plate.
- When switching off inductive loads, voltage spikes are produced that may impair the operation of control and measuring systems. Inductive loads should be provided with commercial arc suppressor RC combinations, e. g. 0.1 $\mu\text{F}/100 \Omega$.

Tools

- Screwdriver for slotted screws, size 2.5, completely insulated according to VDE 0680

Commissioning Procedure

Checking electrical connection

Make sure that the NRS 2-4 and the associated level electrode NRG 211 are wired in accordance with the wiring diagram. **Fig. 3**

Applying mains voltage

Apply mains voltage. The green LED **B** is illuminated. **Fig. 2**



Danger

The screw-type connector of the NRS 2-4 c/d is live during operation. This presents the danger of electric shock!

Cut off power supply before inserting or removing the 19" slide-in unit and before carrying out any installation or maintenance work.

Performance test

NRS 2-4 c/d

1. When switching on the mains voltage the green LED **B** must be permanently illuminated. **Fig. 2**
2. Raise water level until it exceeds the high level mark. The red LED **E** of the level switch must light up.
3. Lower water level until it falls below the high level mark. The red LED must go out.
4. After detaching the connector from the level electrode the amber LED **C** must light up (malfunction in connecting line).
5. After bridging the terminals C16 and C18 the amber LED **D** must light up (malfunction in equipment). The measuring voltages for the operating conditions are listed in table 1.

Table 1

Measuring voltage U_M	Decoding
$\leq 1 V$	Malfunction in electrode supply cable (short circuit or interruption)
$1 V - 4 V$	Electrode exposed, fluid temperature $\geq 395 ^\circ C$
$4 V - 7 V$	Electrode submerged, HIGH level
$\geq 9 V$	Malfunction in electrode (defective insulating seal, leaky stuffing box)

Operational Malfunctions



Danger

The screw-type connector of the NRS 2-4 c/d is live during operation.

This presents the danger of electric shock!

Cut off power supply before inserting or removing the 19" slide-in unit and before carrying out any installation or maintenance work.

Fault finding list for troubleshooting

LED "Power" is not illuminated.

Fault: Power failure

Remedy: Measure voltage across A/C 28 and A/C 30, check voltage supply and electric connection

LED "Malfunction in level electrode" and LED "High level alarm" are illuminated.

Fault: The safety screw of the level electrode has not been removed

Remedy: Remove safety screw

Remedy: Level electrode (insulation, stuffing box) defective

Remedy: Measure measuring voltage across C 18 / A 18
Replace level electrode if measuring voltage ≥ 9 V

LED "Malfunction in connecting line" illuminated.

Fault: Electrode supply line defective (short circuited or interrupted)

Remedy: Check electrode supply line and wiring

High water level is exceeded but only the green LED "Power" is illuminated.

Remedy: Level electrode not submerged

Remedy: Measure measuring voltage across C 18 / A 18
If no voltage can be measured check and, if necessary, change installation of level electrode

Fault: Pre-amplifier in level electrode defective

Remedy: Replace pre-amplifier if the 12 V supply voltage for the electrode is present but no measuring voltage can be measured across C 16 / A 18

If faults occur that are not listed above or cannot be corrected, please contact our service centre or authorized agency in your country.

Annex

Note on the Declaration of Conformity / Declaration by the Manufacturer CE

For details on the conformity of our equipment according to the European Directives see our Declaration of Conformity or our Declaration of Manufacturer.

The current Declaration of Conformity / Declaration of Manufacturer are available in the Internet under www.gestra.de/documents or can be requested from us.

For your notes



Agencies all over the world: www.gestra.de

GESTRA AG

Münchener Straße 77

28215 Bremen

Germany

Telefon +49 421 3503-0

Telefax +49 421 3503-393

E-mail info@de.gestra.com

Web www.gestra.de